



# Investor Presentation

August 2022



# Forward Looking Statements



Certain statements in this document constitute "forward-looking information" or "forward-looking statements" (collectively, "forward-looking statements"). Any such forward-looking statements are intended to provide information about management's current expectations and plans and may not be appropriate for other purposes. Forward-looking statements may include financial and other projections, as well as statements regarding our future plans, strategic objectives or economic performance, or the assumptions underlying any of the foregoing, and other statements that are not recitations of historical fact. We use words such as "may", "would", "could", "should", "will", "likely", "expect", "anticipate", "believe", "intend", "plan", "aim", "forecast", "outlook", "project", "estimate", "target" and similar expressions suggesting future outcomes or events to identify forward-looking statements. The following table identifies the material forward-looking statements contained in this document, together with the material potential risks that we currently believe could cause actual results to differ materially from such forward-looking statements. Readers should also consider all of the risk factors which follow below the table:

Material Forward-Looking Statement	Material Potential Risks Related to Applicable Forward-Looking Statement
Light Vehicle Production	<ul style="list-style-type: none"> <li>Light vehicle sales levels</li> <li>Supply disruptions, including as a result of the current semiconductor chip shortage and/or Russia's invasion of Ukraine</li> <li>Production allocation decisions by OEMs</li> <li>The impact of Russia's invasion of Ukraine on industry production volumes</li> <li>The impact of rising interest rates and availability of credit on consumer confidence and, in turn, vehicle sales and production</li> </ul>
Total Sales Segment Sales Sales Growth over Market	<ul style="list-style-type: none"> <li>Supply disruptions, including as a result of a semiconductor chip shortage, and/or Russia's invasion of Ukraine</li> <li>The impact the Russian invasion of Ukraine on global economic growth, as well as potential disruption of energy supply to Western European operations</li> <li>Elevated levels of inflation</li> <li>The impact of rising interest rates and availability of credit on consumer confidence and, in turn, vehicle sales and production</li> <li>Regional energy shortages and price increases</li> <li>Concentration of sales with six customers</li> <li>Shifts in market shares among vehicles or vehicle segments</li> <li>Shifts in consumer "take rates" for products we sell</li> </ul>
2023, 2024 & 2027: • Powertrain electrification Managed Sales • Battery Enclosures Sales • ADAS Sales	<ul style="list-style-type: none"> <li>Same risks as for Total Sales/Segment Sales/Sales Growth over market</li> <li>Consumer adoption of electrified vehicle offerings and ADAS features</li> <li>Our ability to grow sales with new entrant electric vehicle OEMs</li> <li>Our ability to consistently develop and commercialize innovative products or processes</li> <li>Intellectual property risks</li> </ul>
Adjusted EBIT Margin  Net Income Attributable to Magna	<ul style="list-style-type: none"> <li>Same risks as for Total Sales/Segment Sales/Sales Growth over market</li> <li>Operational underperformance</li> <li>Higher costs incurred to mitigate the risk of supply disruptions, including: materials price increases; higher-priced substitute supplies; premium freight costs to expedite shipments; production inefficiencies due to production lines being stopped/restarted unexpectedly based on customers' production schedules; and price increases from sub-suppliers that have been negatively impacted by production inefficiencies</li> <li>Price concessions</li> <li>Commodity cost volatility</li> <li>Higher labour costs</li> <li>Tax risks</li> </ul>
Equity Income	<ul style="list-style-type: none"> <li>Same risks as Adjusted EBIT Margin Net Income Attributable to Magna</li> <li>Risks related to conducting business through joint ventures</li> </ul>
Free Cash Flow	<ul style="list-style-type: none"> <li>Same risks as for Total Sales/Segment Sales/Sales Growth over Market, and Adjusted EBIT Margin/Net Income Attributable to Magna</li> </ul>

# Forward Looking Statements



Forward-looking statements are based on information currently available to us and are based on assumptions and analyses made by us in light of our experience and our perception of historical trends, current conditions and expected future developments, as well as other factors we believe are appropriate in the circumstances. While we believe we have a reasonable basis for making any such forward-looking statements, they are not a guarantee of future performance or outcomes. In addition to the factors in the table above, whether actual results and developments conform to our expectations and predictions is subject to a number of risks, assumptions and uncertainties, many of which are beyond our control, and the effects of which can be difficult to predict, including, without limitation:

<p><b>Risks Related to the Automotive Industry</b></p> <ul style="list-style-type: none"> <li>economic cyclicality;</li> <li>regional production volume declines;</li> <li>intense competition;</li> <li>potential restrictions on free trade;</li> <li>trade disputes/tariffs;</li> </ul> <p><b>Customer and Supplier Related Risks</b></p> <ul style="list-style-type: none"> <li>concentration of sales with six customers;</li> <li>emergence of potentially disruptive Electric Vehicle OEMs, including risks related to limited revenues/operating history of new OEM entrants;</li> <li>OEM consolidation and cooperation;</li> <li>shifts in market shares among vehicles or vehicle segments;</li> <li>shifts in consumer "take rates" for products we sell;</li> <li>dependence on outsourcing;</li> <li>quarterly sales fluctuations;</li> <li>potential loss of any material purchase orders;</li> <li>a deterioration in the financial condition of our supply base;</li> </ul> <p><b>Manufacturing/Operational Risks</b></p> <ul style="list-style-type: none"> <li>risks arising from Russia's invasion of Ukraine and compliance with the sanctions the regime imposed in response;</li> <li>impact of the semiconductor chip shortages on OEM production volumes and on the efficiency of our operations;</li> <li>risks related to COVID-19;</li> <li>supply disruptions and higher costs to mitigate such disruptions;</li> <li>regional energy shortages and price increases;</li> <li>skilled labour attraction/retention;</li> <li>product and new facility launch risks;</li> <li>operational underperformance;</li> <li>restructuring costs;</li> <li>impairment charges;</li> <li>labour disruptions;</li> <li>climate change risks;</li> <li>leadership succession;</li> </ul>	<p><b>IT Security/Cybersecurity Risk</b></p> <ul style="list-style-type: none"> <li>IT/Cybersecurity breach;</li> <li>Product Cybersecurity breach;</li> </ul> <p><b>Pricing Risks</b></p> <ul style="list-style-type: none"> <li>Inflationary pressures;</li> <li>pricing risks between time of quote and award of new business;</li> <li>price concessions;</li> <li>commodity cost volatility;</li> <li>declines in scrap steel/aluminum prices;</li> </ul> <p><b>Warranty/Recall Risks</b></p> <ul style="list-style-type: none"> <li>costs related to repair or replacement of defective products, including due to a recall;</li> <li>warranty or recall costs that exceed warranty provision or insurance coverage limits;</li> <li>product liability claims;</li> </ul> <p><b>Acquisition Risks</b></p> <ul style="list-style-type: none"> <li>competition for strategic acquisition targets;</li> <li>inherent merger and acquisition risks;</li> <li>acquisition integration risk;</li> </ul>	<p><b>Other Business Risks</b></p> <ul style="list-style-type: none"> <li>risks related to conducting business through joint ventures;</li> <li>our ability to consistently develop and commercialize innovative products or processes;</li> <li>intellectual property risks;</li> <li>our changing business risk profile as a result of increased investment in electrification and autonomous/assisted driving, including: higher R&amp;D and engineering costs, and challenges in quoting for profitable returns on products for which we may not have significant quoting experience;</li> <li>risks of conducting business in foreign markets;</li> <li>fluctuations in relative currency values;</li> <li>tax risks;</li> <li>reduced financial flexibility as a result of an economic shock;</li> <li>changes in credit ratings assigned to us;</li> </ul> <p><b>Legal, Regulatory and Other Risks</b></p> <ul style="list-style-type: none"> <li>antitrust risk;</li> <li>legal claims and/or regulatory actions against us; and</li> <li>changes in laws and regulations, including those related to vehicle emissions or made as a result of the COVID-19 pandemic.</li> </ul>
--	---	--

In evaluating forward-looking statements or forward-looking information, we caution readers not to place undue reliance on any forward-looking statement. Additionally, readers should specifically consider the various factors which could cause actual events or results to differ materially from those indicated by such forward-looking statements, including the risks, assumptions and uncertainties above which are:

- discussed under the "Industry Trends and Risks" heading of our Management's Discussion and Analysis; and
  - set out in our Annual Information Form filed with securities commissions in Canada, our annual report on Form 40-F filed with the United States Securities and Exchange Commission, and subsequent filings.
- Readers should also consider discussion of our risk mitigation activities with respect to certain risk factors, which can be also found in our Annual Information Form.

# Key Messages

- 1 **Well-positioned to capture growing market opportunities** given systems approach and unique complete vehicle capabilities
- 2 **Operational excellence** to enhance efficiencies and mitigate impacts of challenging environment
- 3 **Strategic portfolio** positions us for sales growth over market and strong free cash flow
- 4 **Untapped potential** to generate profits and grow shareholder value

# Magna Snapshot (NYSE: MGA, TSX: MG)



\* 2022 Sales Outlook \$37.6B – \$39.2B

INVESTOR PRESENTATION - AUGUST 2022

5

# Foundational Strengths Enabling Success & Growth



INVESTOR PRESENTATION - AUGUST 2022

6

# ESG Minded from the Start...



Operate efficiently and responsibly



Fair treatment of employees



Contributing to communities in which we operate

# Creating a Better World of Mobility, Responsibly

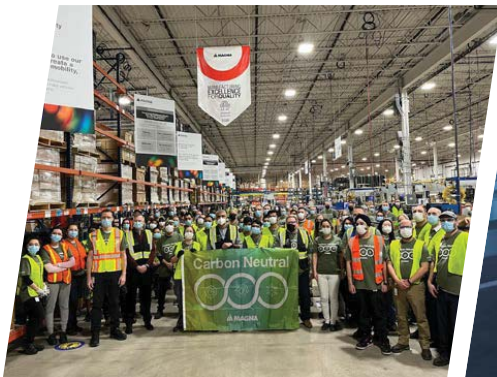

Net Carbon Neutral in Europe by 2025 and all operations by 2030



Technologies that help customers achieve their sustainability goals



Strong, diverse, and inclusive teams

# Secular Trends Driving Change



Electrification



Autonomy



New Mobility

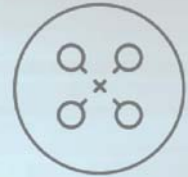

Connectivity

## Magna Positioning

- ✓ Enhanced e-Powertrain portfolio
- ✓ Product range fills transition roadmap to EV
- ✓ New EV business across all products
- ✓ Full ADAS capability
- ✓ Complete system expertise
- ✓ Expanded collaboration ecosystem
- ✓ Leverage new business models
- ✓ Enabling automakers and new entrants
- ✓ Software-enabled functionality in our ECU-related products
- ✓ Optimizing performance and efficiency

## Well Positioned for Car of the Future

# Our Vision

Advancing mobility for everyone and everything.

# Go-Forward Strategy

<p><b>1.</b></p> <p>Accelerate deployment of capital towards high-growth areas</p>	<p><b>2.</b></p> <p>Drive operational excellence</p>	<p><b>3.</b></p> <p>Unlock new business models and markets</p>
--	--	--

# Portfolio Positively Impacted by Megatrends

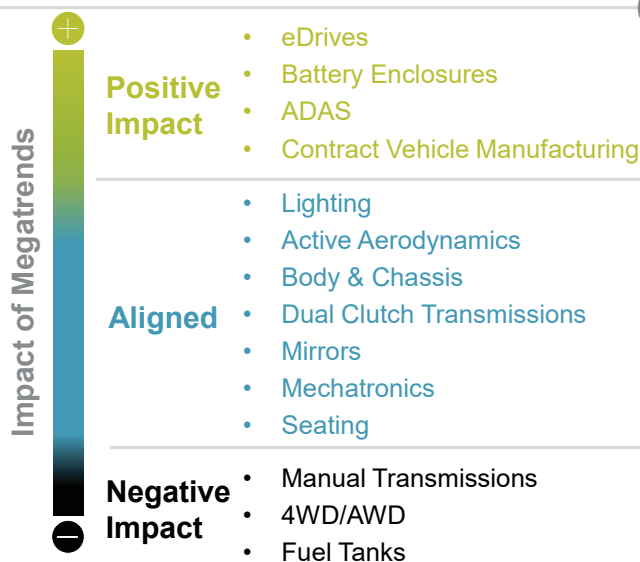

Magna Sales over time

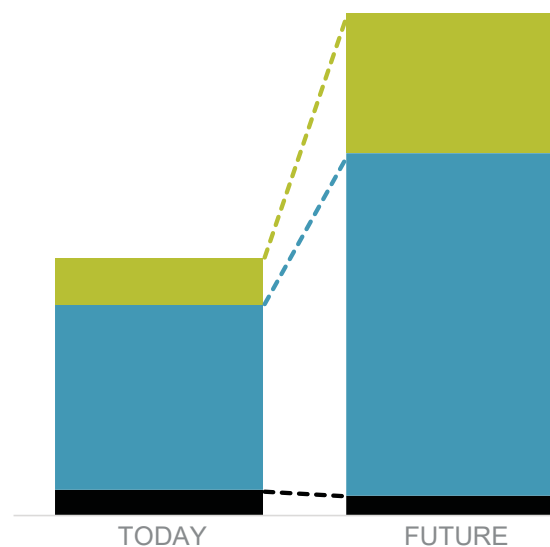



# Key Growth Contributors



## Powertrain Electrification<sup>1</sup>

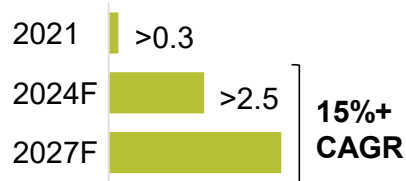

## Battery Enclosures

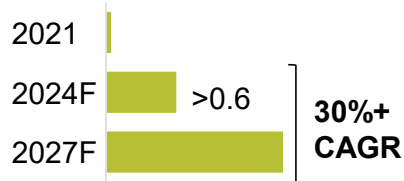

## ADAS

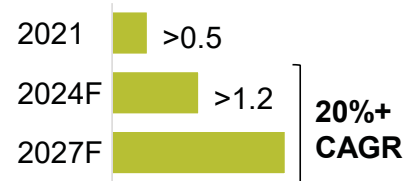

■ Sales in \$Billions

<sup>1</sup> Represents managed sales. Managed sales = consolidated sales + sales at 100% for unconsolidated entities.

# Electrification Business Growing Rapidly



2 eDrive program launches



2 high-volume hybrid DCT program launches



Sales growing at >50% CAGR over outlook period in LG-Magna JV

# Key Wins in Electrification

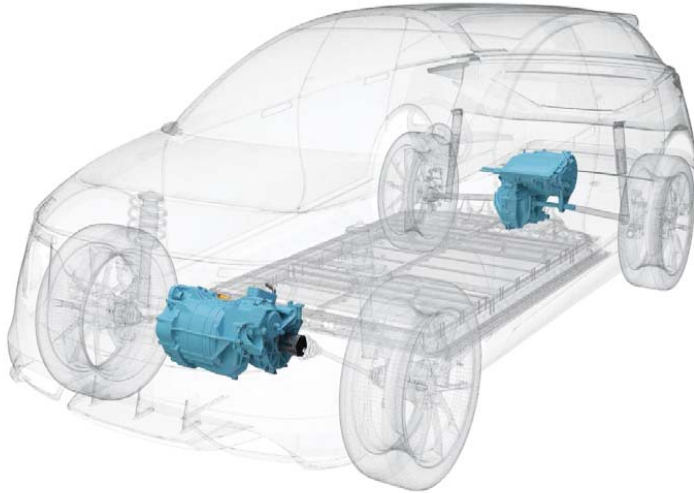

- Primary and secondary eDrives
  - New entrant OEM
  - European OEM
- DCT platform business including hybrid DCTs with Mercedes
- eDrive with China-based OEM

# Electrifying Trucks Without Compromise



## EtelligentForce

- Uncompromised towing and payload
- Minimal disruption to vehicle platform and OEM assembly
- Significant customer interest



# Accelerating Powertrain Electrification Growth

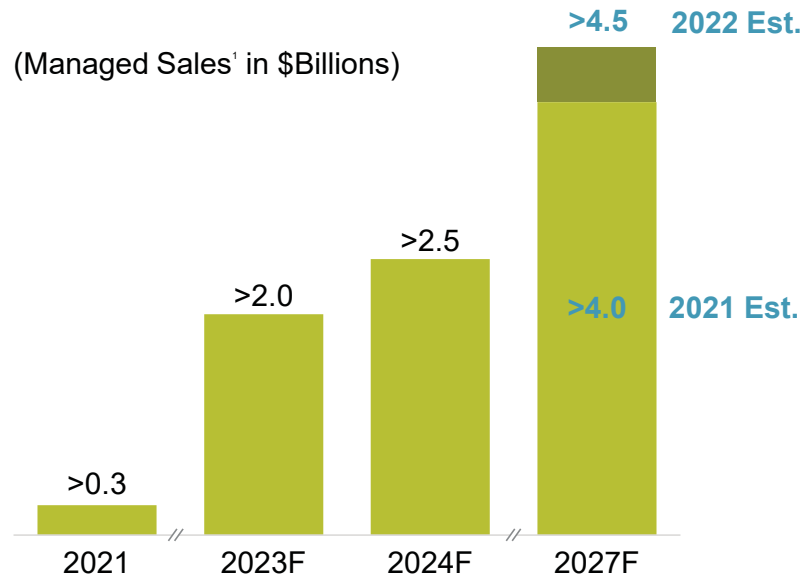

<sup>1</sup> Managed sales = consolidated sales + sales at 100% for unconsolidated entities.

# Battery Enclosures – Growing Addressable Market



- Large, high content, highly engineered product
- Multi-materials and processes
- Investing capital while leveraging existing know-how and installed capacity
- Launching on the GMC Hummer EV and Ford F-150 Lightning

# Battery Enclosures – Growing Addressable Market

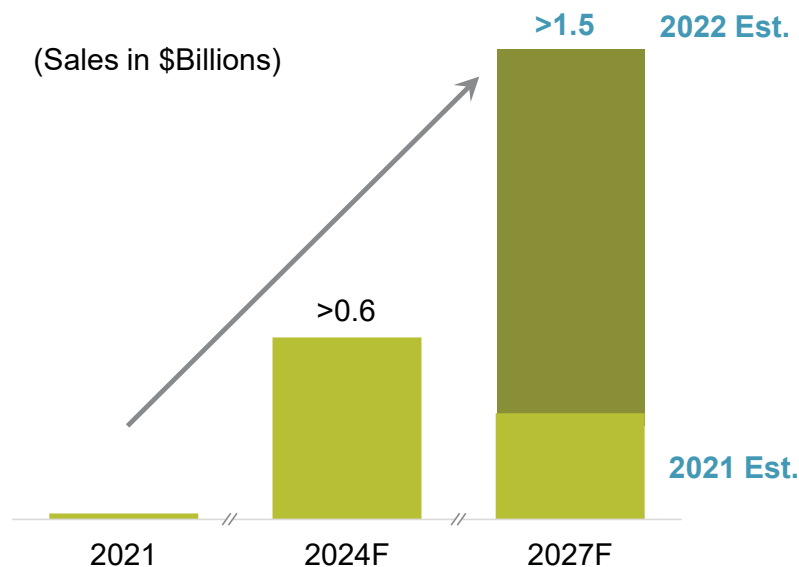

# ADAS Business – Launching



Front camera system and near-field perception software



Surround-view camera system

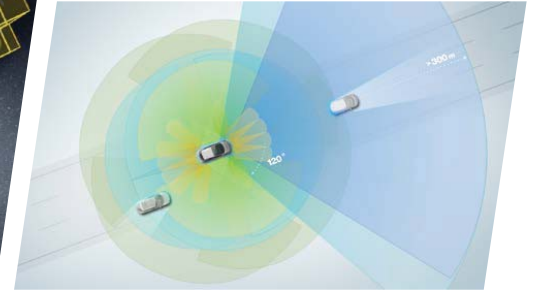

Complete ADAS system

# ADAS Business Growing – Key Wins



- Advanced front camera programs
- Surround View system on Toyota Tundra
- Two Driver Monitoring Systems (DMS)

# Full Systems Capability



- Complete sensor suite, domain controller and software
- Scalable system approach enabling L2+ features
- Enhanced vehicle intelligence delivering a complete ADAS experience

# Accelerating ADAS Growth

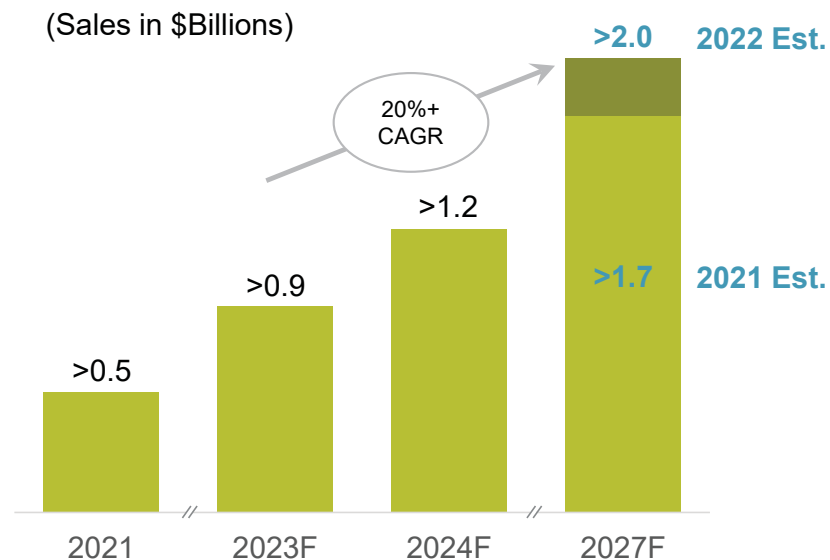

# Leading Market Positions in Aligned Product Areas

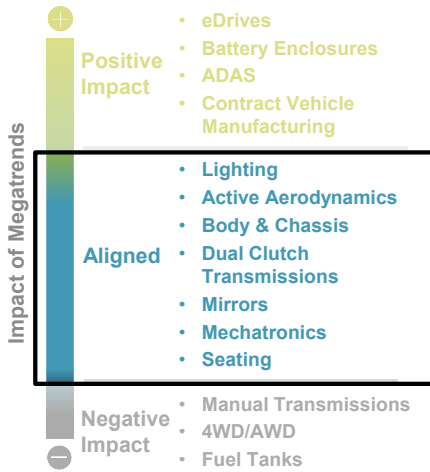

2021 Sales by Product Area (in Billions)



Magna Sales over time

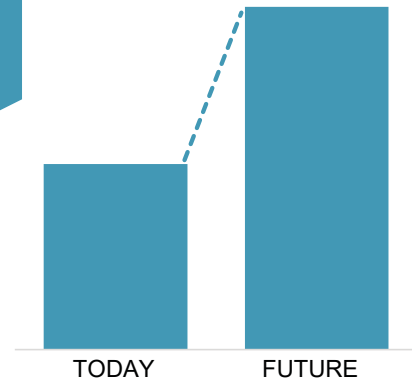

# The Power of Magna



Deep product expertise

Integrated systems approach

Complete vehicle engineering and manufacturing

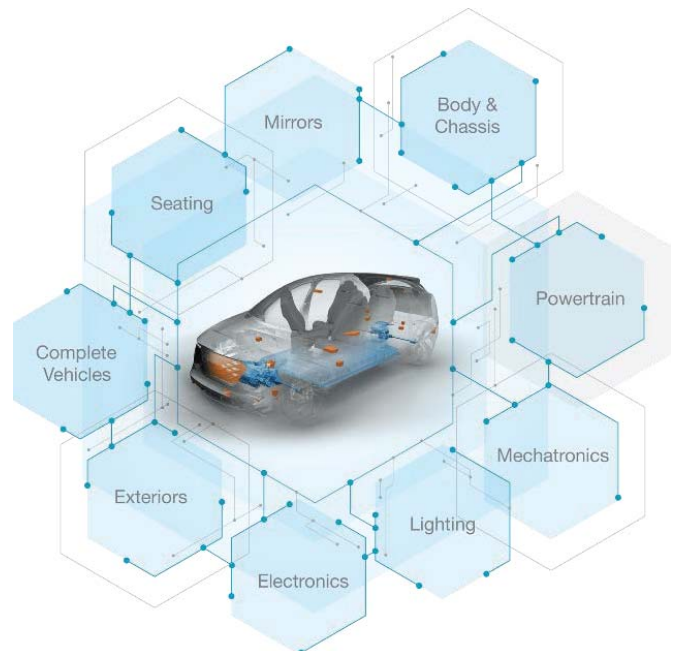

# Expecting Growth and Meaningful Shift in Product Portfolio

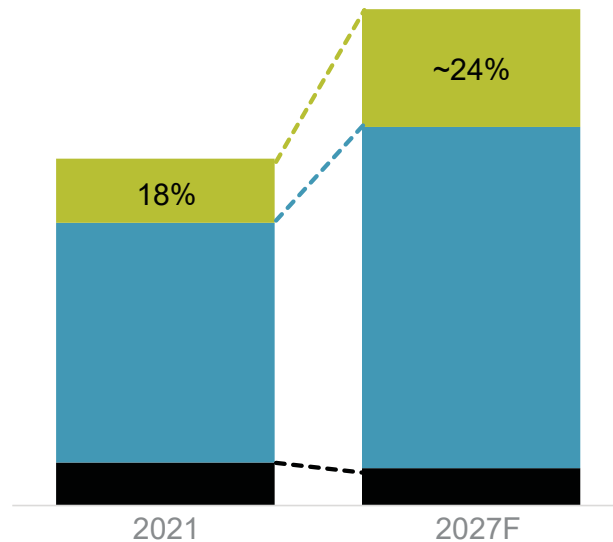

# Foundation of Operational Excellence





# Operational Excellence Driving Success

(2021)

**~\$7B** average annual sales on vehicle launches

**40bps** improved quality costs/sales

**122** customer recognitions (record)

**1.7B** parts shipped

**\$9B+** average annual sales on new business awards

## Building the Factories of the Future

### Factory Digitalization



- Timely, data-driven decisions
- Rapid scaling
- Improve quality, reduce costs

### Data Analytics Drive Predictive Tool Maintenance

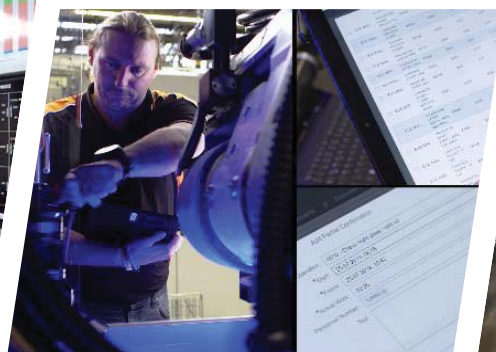

- Improves quality, lower scrap, eliminates other processes
- Maximizes tool utilization
- Scalable across multiple processes

### End of Line Quality Inspection Using Augmented Reality



- 40% reduction in inspection cycle time
- Improves quality control
- Easily scaled: 65 divisions in 6 months

# Established Track Record



- Produced >3.7 million vehicles
- Scaling business
- Integrating new building blocks
- Speed to market
- Continuous improvement mindset

## Vehicles In Production



**Mercedes-Benz G-Class**  
since 1979



**BMW 5 series**  
since 2017



**Jaguar E-PACE**  
since 2017



**Jaguar I-PACE**  
since 2018



**BMW Z4**  
since 2018



**Toyota GR Supra**  
since 2019



**Arcfox αT**  
since 2020



**Arcfox αS**  
since 2021

# Expanding Ecosystem



beyond just cars

## Product Manufacturing

Manufacturing and assembly

## Lifecycle Services

Operational and consumer services connected to the product/vehicle

## Mobility Infrastructure

Offerings adjacent to vehicle service that enhance vehicle usage, efficiency, or adoption



# Financial Strategy

## Strong 5 Year Performance

2017-2021

Average Weighted Sales  
Growth Over Market (GoM)<sup>1</sup>

**6%**

*Growth Over Market in Every Year*

Investment in Business

**\$10.8B**

Return of Capital

**\$7.4B**

Total Shareholder Return (NYSE)

**112%**

*Peer Average of 29%*

<sup>1</sup> Weighted Growth over Market (GoM) compares organic sales growth (%) to vehicle production change (%) after applying Magna geographic sales weighting, excluding Complete Vehicles, to regional production

# Capital Allocation Principles

## Maintain Strong Balance Sheet

- Preserve liquidity and high investment grade credit ratings
  - Adj. debt to Adj. EBITDA ratio between 1.0-1.5x
- Maintain investment flexibility

## Invest for Growth

- Organic and inorganic opportunities
- Innovation

## Return Capital to Shareholders

- Continued dividend growth over time
- Repurchase shares with excess liquidity

# M&A Aligned with Our Strategy



## STRATEGIC FILTERS

- Expands/Complements Technology Base
- Technologies that Enable Acceleration in Megatrend Areas (e.g., electrification, autonomy)
- Customer Diversification
- Geographic Expansion

# Projected Operating Cash Flow Uses 2022-2024

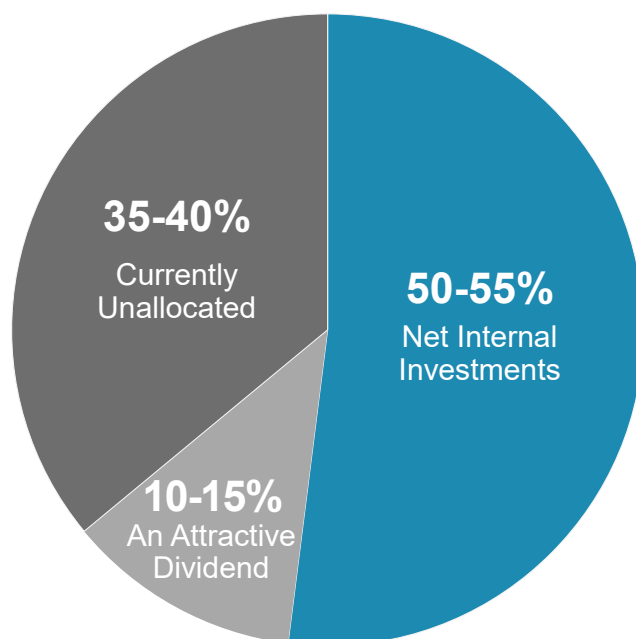

Plus: debt capacity increases as EBITDA grows

# Continued Financial Flexibility



(\$M)

TOTAL LIQUIDITY (06/30/22)	
Cash	\$1,664
Available Term & Operating Lines of Credit	\$3,541
<b>Total Liquidity</b>	<b>\$5,205</b>

LEVERAGE RATIO (LTM, 06/30/22)	
Adjusted Debt	\$5,275
Adjusted EBITDA	\$3,565
Adjusted Debt / Adjusted EBITDA	1.48

Investment-grade ratings from Moody's, S&P, DBRS

Estimated Future LTD Principal Repayments (12/31/21)  
(\$M)

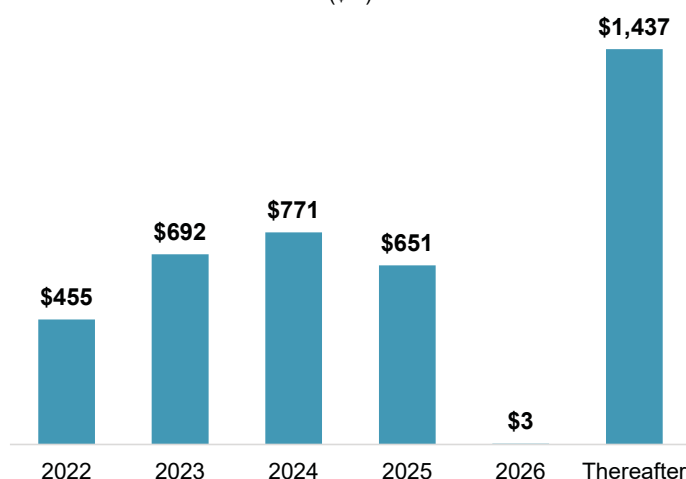

# Q2 2022 Financial Results



## Consolidated Sales (\$Billions)

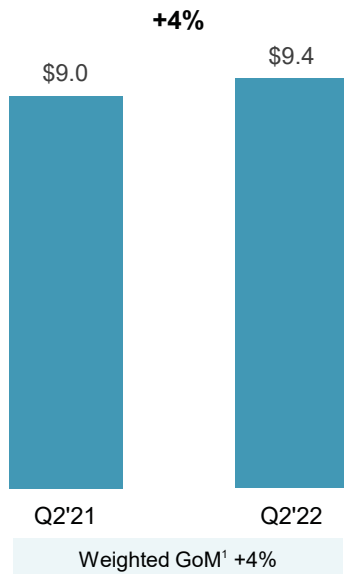

### Q2'22 Production

Global	+2%
North America	+14%
Europe	-1%
China	-5%
Magna Weighted	+8%

## Key Factors

- Higher global light vehicle production and assembly volumes (+)
- Launch of new programs (+)
- Price increases to recover higher input costs (+)
- Foreign currency translation: \$629M (-)
- Lower sales at facilities in Russia (-)
- Divestitures, net of acquisitions: \$83M (-)
- Customer price concessions (-)

<sup>1</sup> Weighted Growth over Market (GoM) compares organic sales growth (%) to vehicle production change (%) after applying Magna geographic sales weighting, excluding Complete Vehicles, to regional production

# Q2 2022 Financial Results



## Adjusted EBIT & Margin (\$Millions)

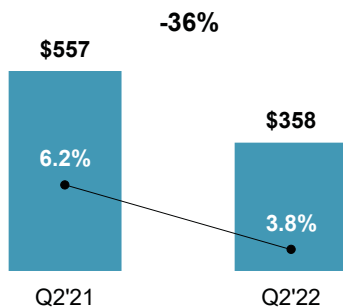

### Most Significant Factor

- Higher net input costs (-)

### Other Items

- Operating inefficiencies and other costs at a facility in Europe (-)
- Reduced earnings on lower sales at facilities in Russia (-)
- Favourable value-added tax settlement in Brazil in Q2'21 (-)
- Lower tooling contribution (-)
- Lower equity income (-)
- Higher favourable commercial settlements (+)
- Lower net warranty costs (+)
- Divestitures, net of acquisitions (+)

## Adjusted EPS (\$)

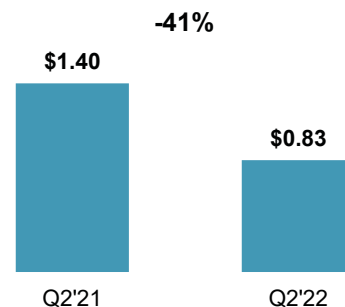

### Adjusted effective tax rate of 24.9% vs 19.8% in Q2'21:

- Lower favourable changes in reserves for uncertain tax positions (-)
- Higher losses not benefitted in Europe (-)
- Change in the mix of earnings (+)

**Adjusted Net Income Attributable to Magna** of \$243M, down \$183M

# Financial Outlook – Key Assumptions



	2021	APRIL 2022	JULY 2022
<b>Light Vehicle Production</b> (millions of units)			
• North America	13.1	14.7	14.7
• Europe	16.0	16.4	16.4
• China	24.6	24.4	24.4
<b>Foreign Exchange Rates</b>			
• 1 CDN dollar equals USD	0.798	0.790	0.783
• 1 EURO equals USD	1.183	1.091	1.052
• 1 RMB equals USD	0.155	0.157	0.151

Changed from previous Outlook

INVESTOR PRESENTATION - AUGUST 2022

40

# 2022 Outlook

(\$Billions, unless otherwise noted)



	2021	APRIL 2022	JULY 2022
<b>Sales:</b>			
• Body Exteriors & Structures	14.5	15.8 – 16.4	16.0 – 16.6
• Power & Vision	11.3	11.6 – 12.0	11.7 – 12.1
• Seating Systems	4.9	5.2 – 5.5	5.3 – 5.6
• Complete Vehicles	6.1	5.2 – 5.5	5.1 – 5.4
<b>Total Sales</b>	36.2	37.3 – 38.9	37.6 – 39.2
Adjusted EBIT Margin % <sup>1</sup>	5.7%	5.0% – 5.4%	5.0% – 5.4%
Equity Income	148M	70M – 100M	70M – 100M
Interest Expense	78M	~90M	~80M
Income Tax Rate <sup>2</sup>	19.8%	~21%	~21%
Net Income Attributable to Magna <sup>3</sup>	1.553	1.3 – 1.5	1.3 – 1.5
Capital Spending	1.4	~1.8	~1.8

Changed from previous Outlook

<sup>1</sup> Adjusted EBIT Margin is the ratio of Adjusted EBIT to Total Sales

<sup>2</sup> The Income Tax Rate has been calculated using Adjusted EBIT and is based on current tax legislation

<sup>3</sup> Net Income Attributable to Magna represents Net Income excluding Other expense (income), net

INVESTOR PRESENTATION - AUGUST 2022

41

# Free Cash Flow<sup>1</sup> Expectations



2022  
(\$Billions)

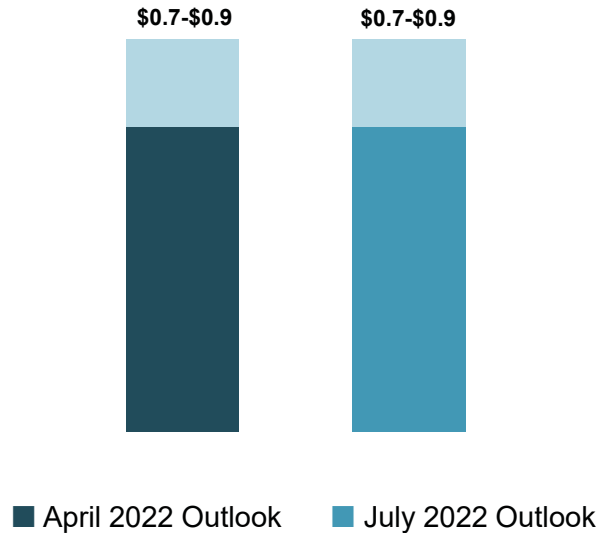

<sup>1</sup> Free Cash Flow is Cash from Operating Activities plus proceeds from normal course dispositions of fixed and other assets plus settlement of long-term receivable from a non-consolidated joint venture minus capital spending minus investment in other assets

# Executing Our Disciplined Profitable Growth Strategy



## Strategy

Accelerate deployment of capital towards high-growth areas

Drive operational excellence

Unlock new business models and markets

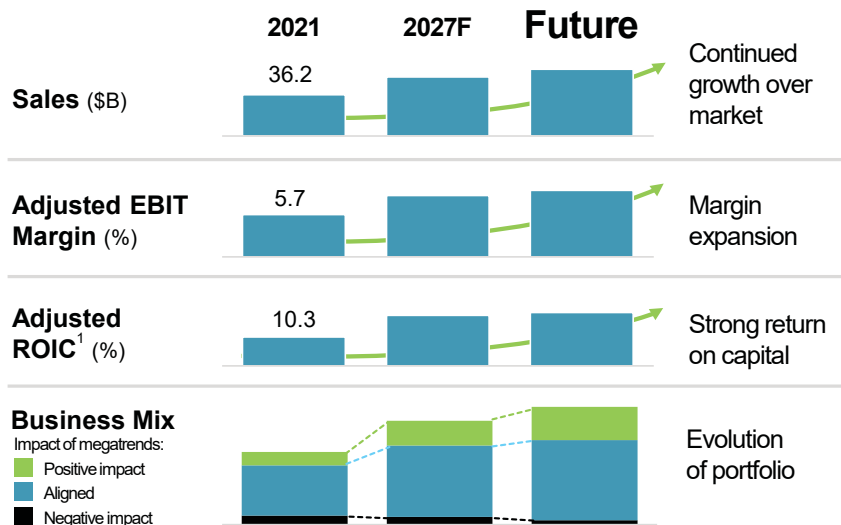

<sup>1</sup> Adjusted Return on Invested Capital (Adjusted ROIC) is calculated as Adjusted After-tax operating profits divided by Average Invested Capital for the period. Please see Magna's 2021 Annual Report for detailed calculation.



# Investment Summary

- 1 **Well-positioned to capture growing market opportunities** given systems approach and unique complete vehicle capabilities
- 2 **Operational excellence** to enhance efficiencies and mitigate impacts of challenging environment
- 3 **Strategic portfolio** positions us for sales growth over market and strong free cash flow
- 4 **Untapped potential** to generate profits and grow shareholder value

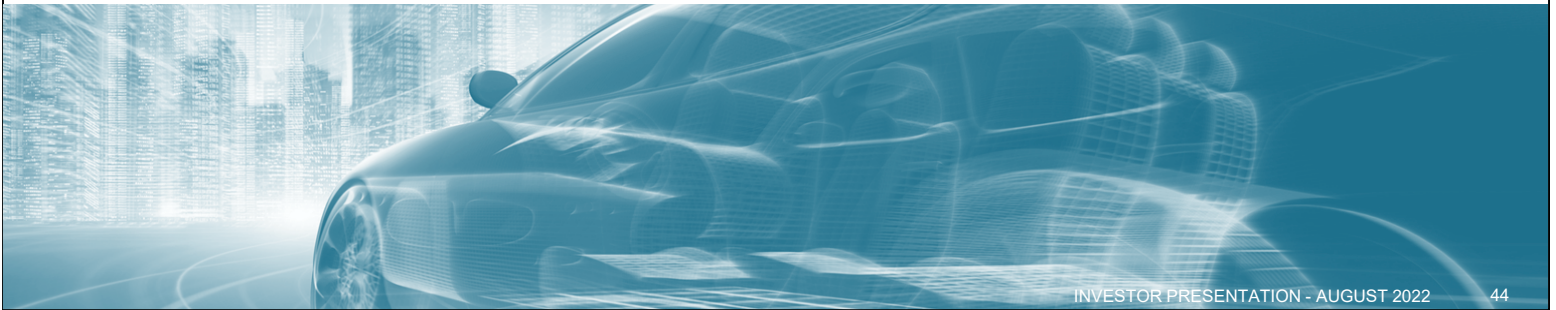

# APPENDIX

# Bringing Power to the Wheels



## MODULAR & SCALABLE BUILDING BLOCKS

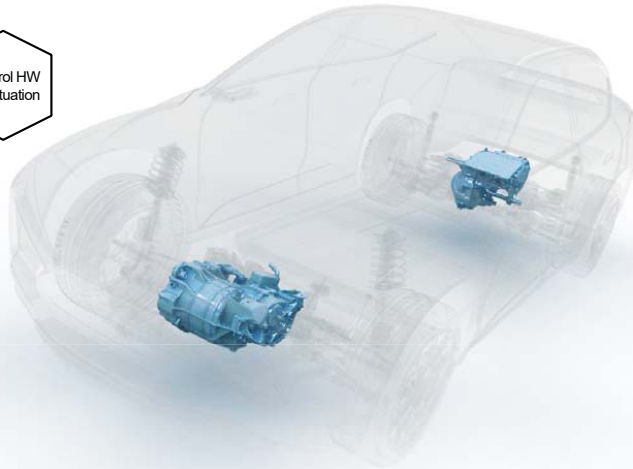
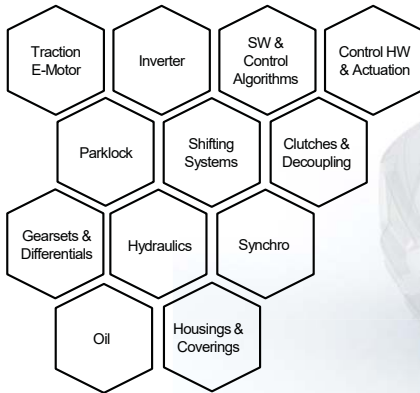

## MODULAR & SCALABLE PRODUCTS

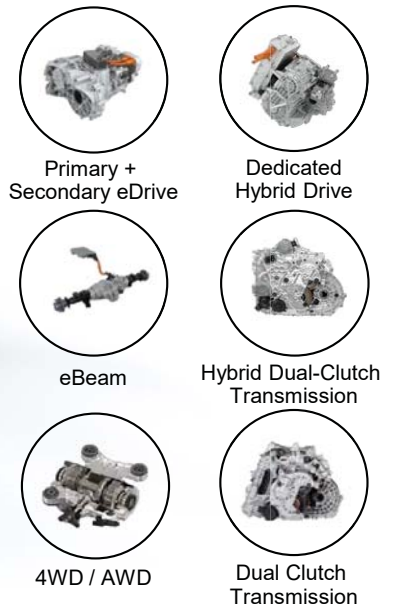

# Well-Positioned to Capture Growing EV Opportunity

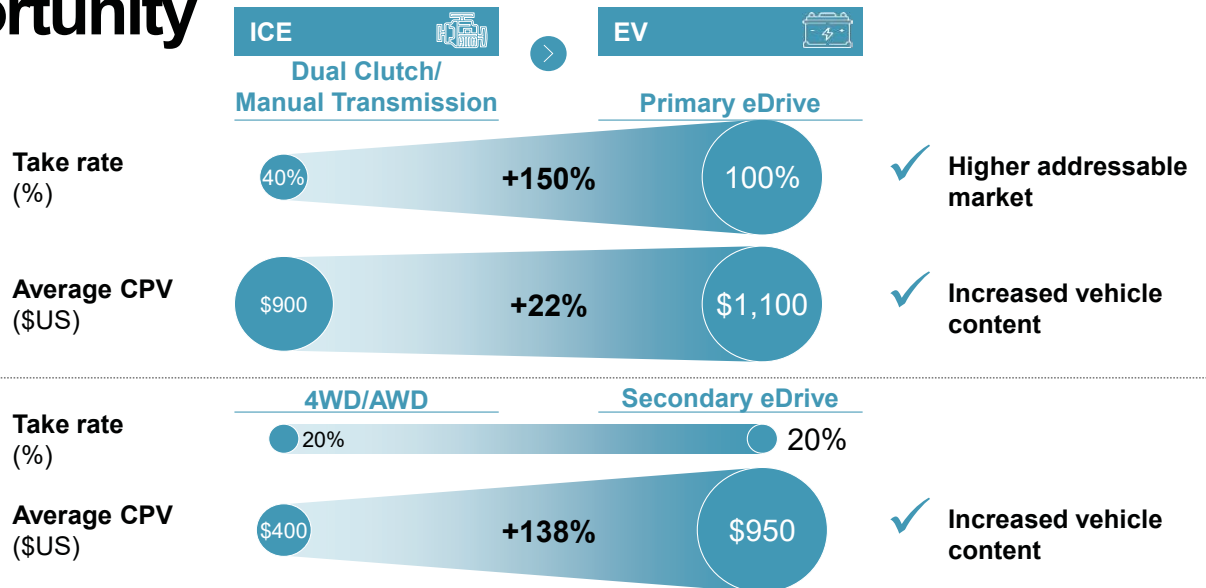

Higher Content Opportunity and Addressable Market for Magna as EV Transition Unfolds

# Complete System Integration and Fusion Capabilities

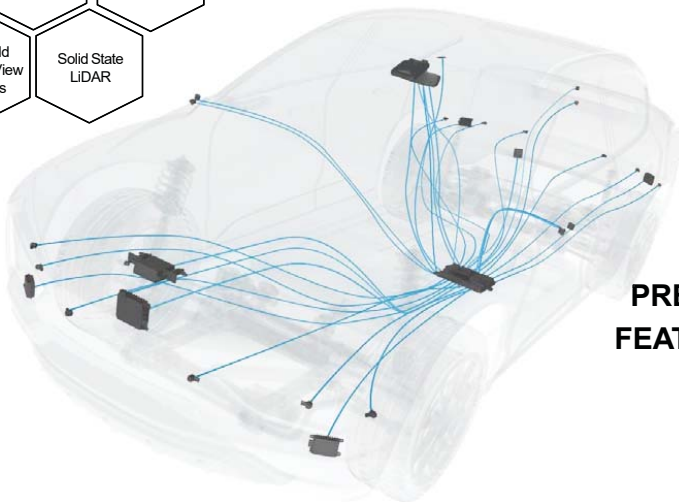
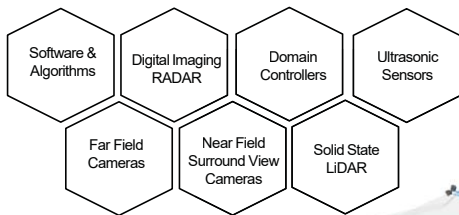

## SAFETY FEATURES (NCAP 5-STAR)



Lane Departure Warning  
Automatic Emergency Braking  
Lane Keep Assist

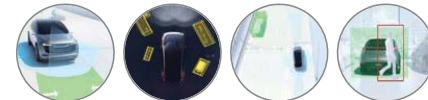

Lane Centering Control  
Surround View  
Adaptive Cruise Control  
Rear Automatic Emergency Braking



Traffic Jam Assist  
Advanced Trailering  
Autonomous Emergency Steering  
Autonomous Valet Park



Highway Pilot  
Connected Powertrain  
Driver & Occupant Monitoring  
Intelligent Lighting  
Advanced Mirror Systems

## PREMIUM FEATURES

# Leveraging Core Building Blocks To Address New Markets

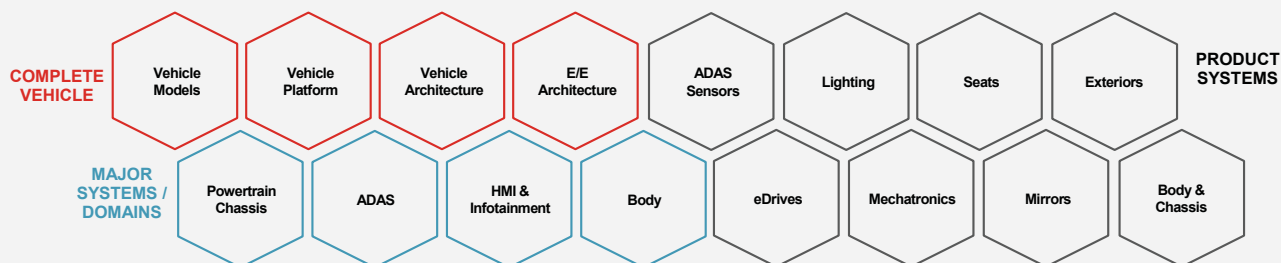

# Innovation Ecosystem



Taping Into Great Thinking  
Outside the Company

Open for Business Mindset

Auto-Qualified Results

Access to New  
Creative Approaches



# Q2 2022

# Sales Performance vs Market



## Q2 2022 vs Q2 2021

	REPORTED	ORGANIC <sup>1</sup>	PERFORMANCE VS WEIGHTED GLOBAL PRODUCTION (Weighted GoM)
Body Exteriors & Structures	8%	15%	7%
Power & Vision	0%	7%	(1%)
Seating Systems	7%	16%	8%
Complete Vehicles	(6%)	7%	(1%)
<b>TOTAL SALES</b>	<b>4%</b>	<b>12%</b>	<b>4%</b>
<b>Unweighted Production Growth</b>	<b>2%</b>		
<b>Weighted Production Growth<sup>2</sup></b>	<b>8%</b>		

<sup>1</sup> Organic Sales represents sales excluding acquisitions net of divestitures and FX movements

<sup>2</sup> Calculated by applying Magna geographic sales weighting, excluding Complete Vehicles, to regional production

INVESTOR PRESENTATION - AUGUST 2022

52

# Sales Performance vs Market



## 2022 YTD vs 2021 YTD

	REPORTED	ORGANIC <sup>1</sup>	PERFORMANCE VS WEIGHTED GLOBAL PRODUCTION (Weighted GoM)
Body Exteriors & Structures	5%	10%	10%
Power & Vision	(2%)	2%	2%
Seating Systems	6%	13%	13%
Complete Vehicles	(20%)	(12%)	(12%)
<b>TOTAL SALES</b>	<b>(1%)</b>	<b>5%</b>	<b>5%</b>
<b>Unweighted Production Growth</b>	<b>(2%)</b>		
<b>Weighted Production Growth<sup>2</sup></b>	<b>0%</b>		

<sup>1</sup> Organic Sales represents sales excluding acquisitions net of divestitures and FX movements

<sup>2</sup> Calculated by applying Magna geographic sales weighting, excluding Complete Vehicles, to regional production

INVESTOR PRESENTATION - AUGUST 2022

53

# Geographic Sales



## Q2 2022 vs Q2 2021

### NORTH AMERICA

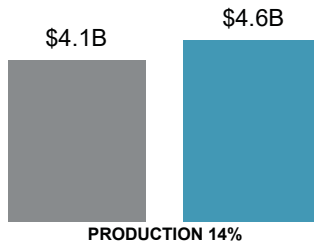

### EUROPE

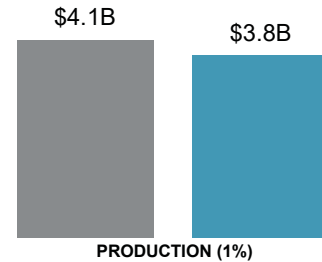

### ASIA

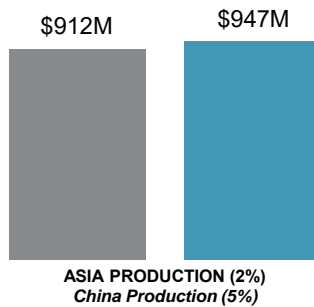

### REST OF WORLD

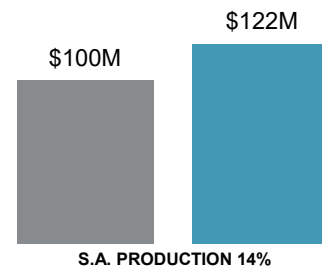

■ Q2 2021 ■ Q2 2022

INVESTOR PRESENTATION - AUGUST 2022

54

# Q2 2022 Cash Flow and Investment Activities



## Free Cash Flow<sup>1</sup>

(\$Millions)

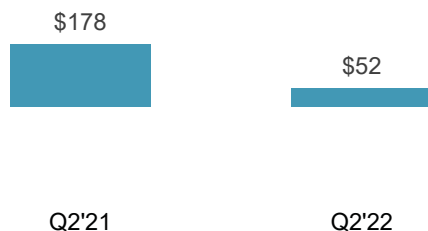

Cash from Operations Before Changes in Operating Assets & Liabilities	\$560M
Changes in Operating Assets & Liabilities	(\$139M)
<b>Cash from Operations</b>	<b>\$421M</b>
Fixed Asset Additions	(\$329M)
Increase in Investments, Other Assets and Intangible Assets	(\$80M)
Proceeds from Dispositions	\$40M
<b>Free Cash Flow<sup>1</sup></b>	<b>\$52M</b>

## OTHER USES OF CASH

Net Repayment of Debt	\$31M
Public and Private Equity Investments	\$2M
Repurchase of Common Shares	\$212M
Dividends (\$0.45/share)	\$130M

<sup>1</sup> Free Cash Flow (FCF) is Cash from Operating Activities plus proceeds from normal course dispositions of fixed and other assets plus settlement of long-term receivable from a non-consolidated joint venture minus capital spending minus investment in other assets

INVESTOR PRESENTATION - AUGUST 2022

55

# Leverage Ratio

(\$Millions)



LTM EBITDA	\$ 3,105
Lease Adjustment	\$ 325
Other	\$ 135
<b>Adjusted EBITDA</b>	<b>\$ 3,565</b>
Debt per Balance Sheet	\$ 3,513
Lease Liability per Balance Sheet	\$ 1,564
Other	\$ 198
<b>Adjusted Debt</b>	<b>\$ 5,275</b>
<b>Adjusted Debt / Adjusted EBITDA (Q2 2022)</b>	<b>1.48x</b>

# Segment Financial Performance

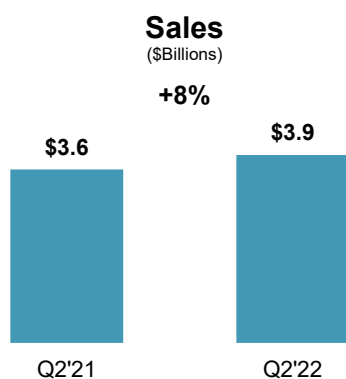

- Higher global light vehicle production (+)
- Launch of new programs (+)
- Price increases to recover higher input costs (+)
- Foreign currency translation: \$180M (-)
- Lower sales at facilities in Russia (-)
- Divestitures, net of acquisitions: \$73M (-)
- Customer price concessions (-)

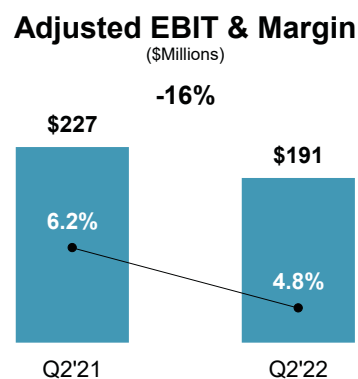

- Higher net input costs (-)
- Operating inefficiencies & other costs at a facility in Europe (-)
- Reduced earnings on lower sales at facilities in Russia (-)
- Lower tooling contribution (-)
- Favourable value-added tax settlement in Brazil in Q2'21 (-)
- Earnings on higher sales (+)
- Higher favourable commercial settlements (+)
- Divestitures, net of acquisitions (+)
- Lower launch costs (+)

# Segment Financial Performance

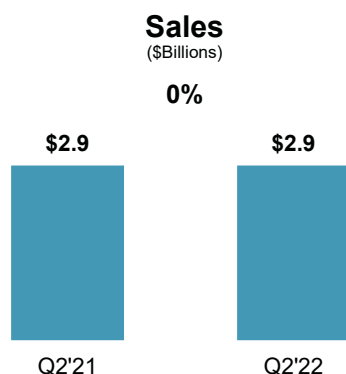

- Launch of new programs (+)
- Higher global light vehicle production (+)
- Customer price increases to recover higher production costs (+)
- Foreign currency translation: \$195M (-)
- Net customer price concessions (-)

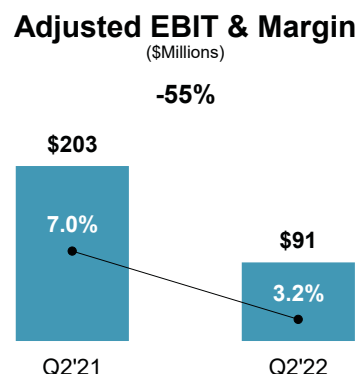

- Higher net input costs (-)
- Lower equity income (-)
- Higher launch costs (-)
- Favourable value-added tax settlement in Brazil in Q2'21 (-)
- Earnings on higher sales (+)
- Lower net warranty costs: \$15M (+)
- Higher net favourable commercial settlements (+)



# Segment Financial Performance



## Sales (\$Billions)

+7%

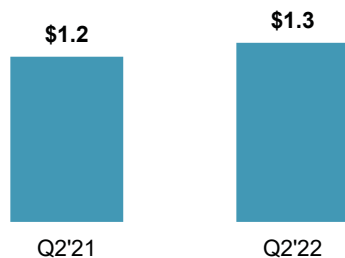

- Higher global light vehicle production (+)
- Launch of new programs (+)
- Customer price increases to recover higher production input costs (+)
- Foreign currency translation: \$84M (-)
- Lower sales at facilities in Russia (-)
- Net customer price concessions (-)

## Adjusted EBIT & Margin (\$Millions)

-92%

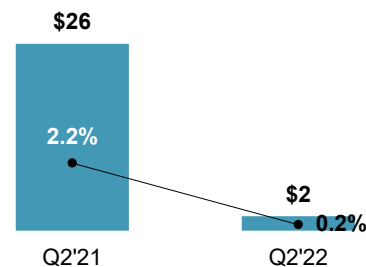

- Higher net input costs (-)
- Higher launch costs (-)
- Reduced earnings on lower sales at facilities in Russia (-)
- Favourable value-added tax settlement in Brazil in Q2'21 (-)
- Productivity and efficiency improvements at certain underperforming facilities (+)
- Earnings on higher sales (+)

# Segment Financial Performance



## Sales (\$Billions)

-6%

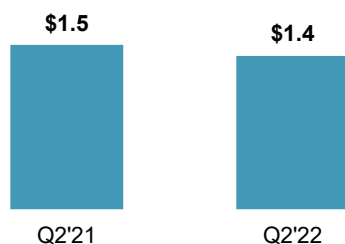

- Weaker euro: \$185M (-)
- Higher vehicle assembly volumes: 1.5K units (+)
- Favourable program mix (+)

## Adjusted EBIT & Margin (\$Millions)

-20%

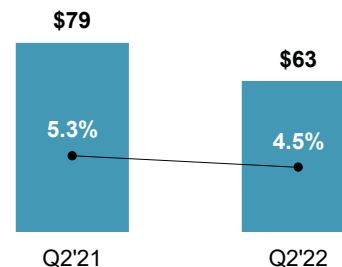

- Weaker euro: \$7M (-)
- Higher net input costs (-)
- Unfavourable program mix (-)
- Higher earnings on higher assembly volumes, net of contractual fixed cost recoveries on certain programs (+)
- Higher margins on engineering programs (+)

# Other

# Significant Content on BEV Launches Globally



Ford F-150 Lightning



Mercedes-Benz EQS SUV



Cadillac Lyriq



Rivian R1S



GMC Hummer



BMW iX



Mercedes-Benz EQE



Volkswagen ID Buzz



Fisker Ocean



NIO ES7

Coming Soon



Xpeng G9



Smart B-SUV

□ North America □ Europe □ China

INVESTOR PRESENTATION - AUGUST 2022

62

# Key 2022 Non-EV Launches



Chevrolet Silverado (Oshawa)



Jeep Wagoneer



Honda CR-V



Toyota Tundra



Ford Maverick



Alpha Romero Tonale



BMW X1



Mercedes-Benz GLC



BMW X5

□ North America □ Europe □ China

INVESTOR PRESENTATION - AUGUST 2022

63

# Magna Segment and Regional Data<sup>1</sup>



2021 Sales by Segment

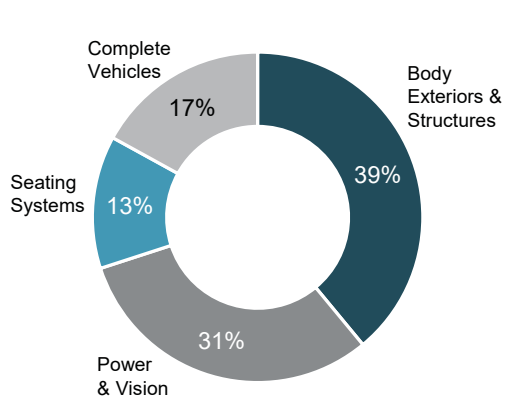

2021 Sales by Geography

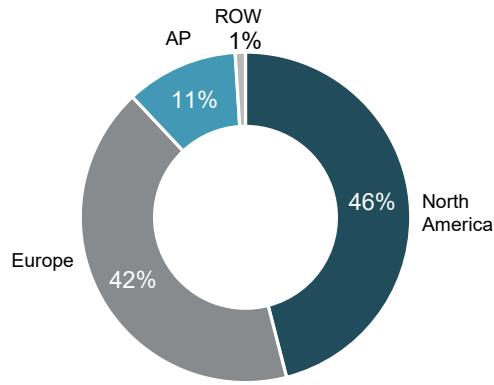

2021 Adjusted EBIT by Segment

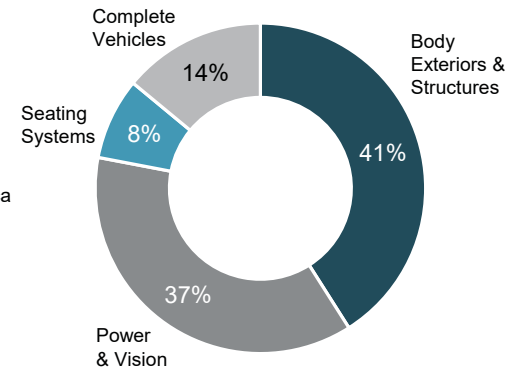

<sup>1</sup> Excluding Corporate segment